



MacLean Power
Systems
7801 Park Place Rd., York, SC 29745
USA (803) 628-2100

MPS Catalog Number **H7 90 20 018 MX SS 009**
Revision: PD-2 Date 4/4/2023

End Fittings
Tower End Fitting: 1 Piece Gain Base (Aluminum)
Line End Fitting: Trunnion

Material
Number of Sheds: 9
Rod Diameter: 1-3/4"
Weight Estimate: 18.0 lbs 8.2 kg

Dimensional Values

Section Length (L):	27.5 in	673 mm
Rubber Length (X):	18.0 in	456 mm
Shed Height (P):	2.4 in	62 mm
Shed Diameter (B):	6.9 in	175 mm
Shed Spacing (S):	2.0 in	52 mm
Dry Arc Distance:	20.8 in	529 mm
Leakage Distance:	58.2 in	1478 mm

Electricals Values

60 Hz dry Flashover:	232 kV	Min. Withstand	198 kV
60 Hz Wet Flashover:	185 kV	Min. Withstand	145 kV
Positive CIFO:	358 kV	Min. Withstand	319 kV
Negative CIFO:	411 kV	Min. Withstand	352 kV

Mechanical Values

Max. Design Cant. Load (MDCL):	1,350 lbs	6.0 kN
Specified Cant. Load (SCL):	2,800 lbs	12.5 kN
Specified Tensile Load (STL):	5,000 lbs	22.2 kN

This drawing contains confidential information that is the property of MacLean Power, L.L.C. ("MacLean"). Use of MacLean's confidential information without MacLean's express written consent is strictly prohibited and may expose you to legal liability. If you believe that you received this material in error, please destroy it or return it to "MacLean Power, L.L.C., 7801 Park Place Rd., York, South Carolina 29745, USA."

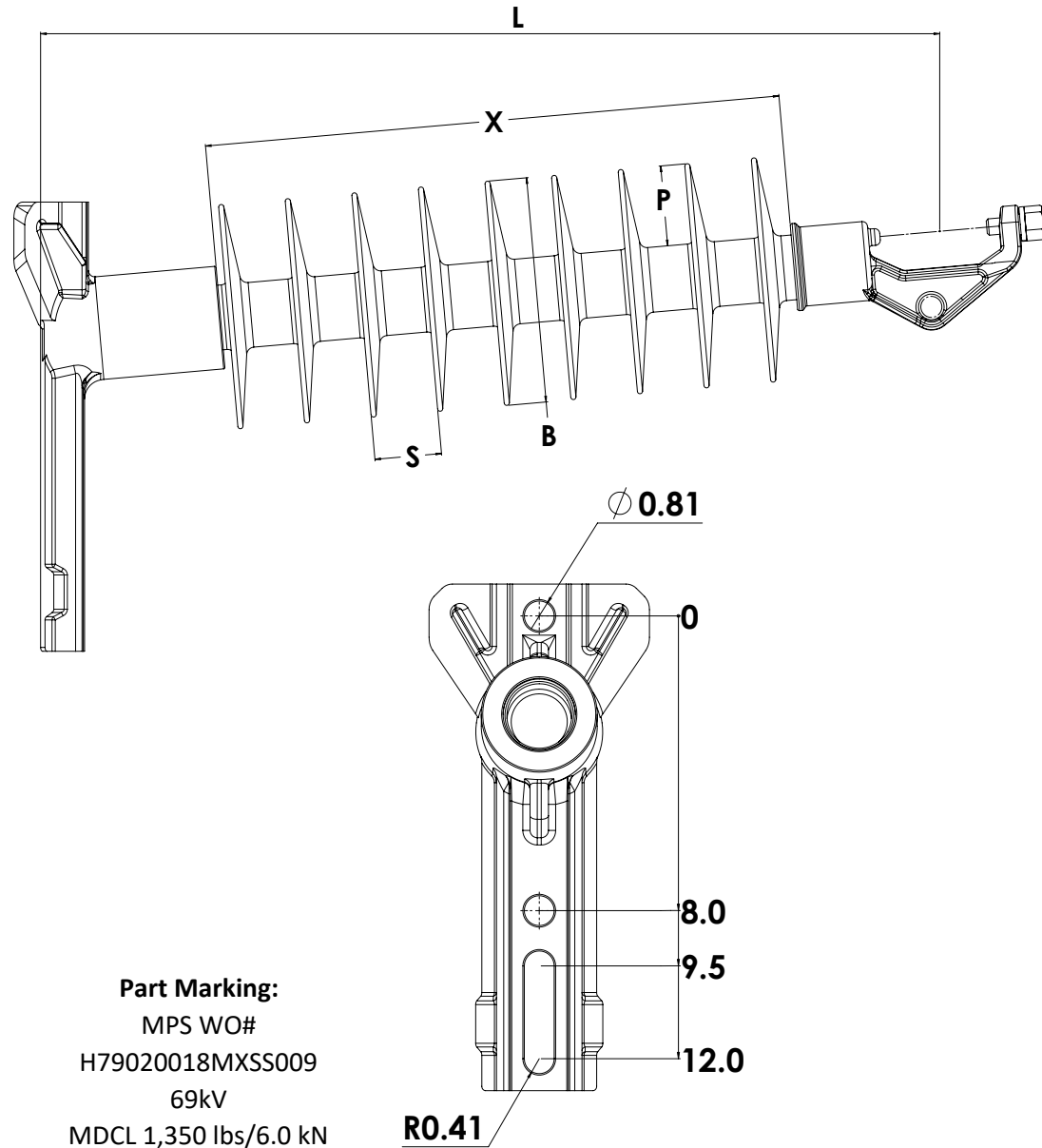

Part Marking:
MPS WO#
H79020018MXSS009
69kV
MDCL 1,350 lbs/6.0 kN

Dimension: inches [millimeters]

NOTE: Drawing not actual depiction of insulator appearance

R0.41

Insulator assembly complies with ANSI C.29.18 and CSA C411.6 Standards